

# SHARP

OUTSTANDING RECEPTION THE WORLD OVER

# SERVICE MANUAL

CB-2170



**SYNTHESIZED 40 CHANNEL  
CITIZENS BAND TRANSCEIVER**

## MODEL CB-2170

This model CB-2170 is almost the same as the model CB-4370 except for the channel display circuit and some external parts. As to the descriptions about "Trouble Shooting Guide", "Cautions on Handling MOS IC" and "Equivalent Circuit of IC", refer to the Service Manual for the MODEL CB-4370.

**"WARNING"**  
It is unlawful for the user to make any replacement or substitution of parts, adjustments or to service the transmitter by any one other than a person holding a commercial 1st or 2nd class radio operator's license. Any change in the circuitry that would change or violate the technical regulations or type acceptance is prohibited.

### SPECIFICATIONS

#### Transmitter section

RF power output ..... 4W (maximum)  
 Frequency range ..... 27MHz Citizens Band  
 Channels ..... 40 chs. P.L.L. (Phase Locked Loop) circuit Synthesizer  
 Type of crystal ..... HC-18U  
 Tolerance  
 10.240MHz . . . . . ± 0.003%  
 Transmitter modulation... 100% (maximum)  
 Modulation limiter..... Yields high average modulation at average voice levels  
 Antenna matching ..... Nominal 50 ohms  
 Carrier deviation ..... Not greater than ± 800Hz nominal on (exceeds F.C.C., D.O.C., etc. requirements)  
 Harmonic suppression..... Exceeds 60dB

#### Receiver section

Audio power output ..... 3.5 Watts maximum power output  
 Sensitivity ..... 0.5µV/m for 10dB S + N/N ratio at 30% at 1000Hz modulation  
 Channels ..... 40 chs. P.L.L. (Phase Locked Loop) circuit Synthesizer  
 Type of crystal ..... HC-18U  
 11.150MHz . . . . . ± 0.003%  
 Selectivity ..... 6dB down at ± 3kHz;  
 60dB down at ± 10kHz.  
 Intermediate frequency.... 1st-IF: 10.695MHz,  
 2nd-IF: 455kHz

Circuit type..... Dual conversion superheterodyne: Phase Locked Loop (P.L.L.) frequency synthesizer provides 40 transmit and receive channels. Delta tuning of ±1.0kHz on each channels plus ceramic filter.  
 Auxiliary circuits ..... Automatic noise limiter (ANL), Variable squelch, Public Address System (P.A.)

#### General

Power source ..... DC 12.0V Nominal negative or positive ground  
 Antenna ..... 50 ohm external antenna for car or base operation  
 Speaker ..... 3-1/8" P.D.S. 8-ohm Imp.  
 Microphone ..... Press-to-talk dynamic microphone (500 ohm)  
 Accessories ..... Microphone hanger  
 Mobile mounting bracket  
 Mounting screws  
 Microphone with plug and cord.  
 Power supply cord with fuse holder and socket.  
 Spare fuse (2.3A)  
 Dimensions ..... 2-17/32" (H) x 6-11/16" (W) x 7-9/16" (D)  
 Weight ..... 3.6 lbs. without microphone  
 Cabinet..... Metal body with plastic front

## SHARP ELECTRONICS CORPORATION

#### Executive Office:

10 Keystone Place, Paramus, New Jersey 07652 (201) 265-5600

#### Regional Offices & Distribution Centers:

10 Keystone Place Paramus, New Jersey 07652 (201) 265-5600

21580 Wilmington Ave., Long Beach, Calif. 90810 (213) 830-4470

U.S. Subsidiary of Sharp Corporation, Osaka, Japan

#### Parts Centers:

P.O. Box 664 Paramus, New Jersey 07652 (201) 265-5600

P.O. Box 20394 Long Beach, Calif. 90801 (213) 830-4470

**PARTS LAYOUT**

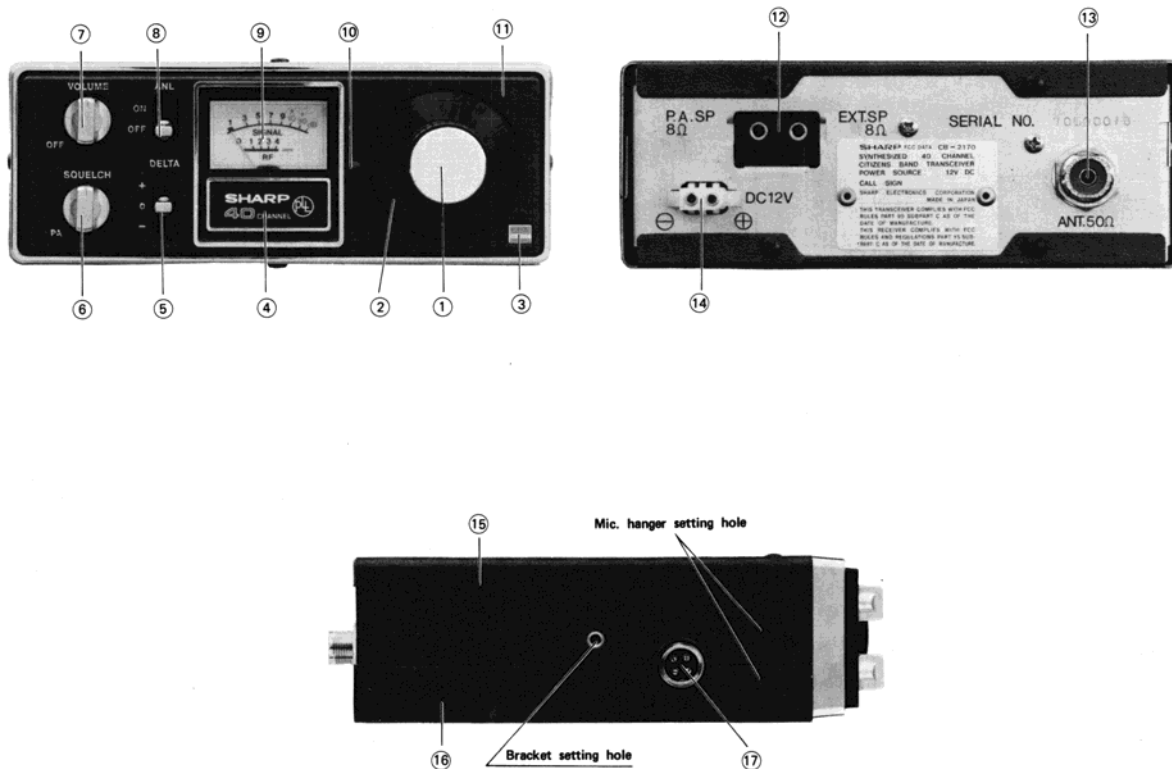

- ① Channel Selector Knob (JKNBN0337AFSA)
- ② Channel Dial (HDALP0369AFSA)
- ③ Emblem "SHARP" (HINDM1080AFSB)
- ④ Decoration Plate, 40 CHANNEL (HBDGS3050AFSA)
- ⑤ Delta Tuning Switch Knob (JKNBM0219AFSA)
- ⑥ Squelch Control with P.A. Switch Knob (JKNBN0300AFSA)
- ⑦ Volume Control with Power Switch Knob (JKNBN0300AFSA)
- ⑧ A.N.L. Switch Knob (JKNBM0219AFSA)
- ⑨ Signal/RF Power Meter (RMTRE0063AFZZ)
- ⑩ Indication, Channel (HINDI0056AFSA)
- ⑪ Front Panel (HPNLC1227AFSA)
- ⑫ Jacks, External Speaker and P.A. Speaker (QJAKB0050AFZZ)
- ⑬ External Antenna Socket, SO401 (QSOCZ2470AFZZ)
- ⑭ Power Supply Plug, PG601 (QSOCZ2454AFZZ)
- ⑮ Cabinet, Top (GCABA3447AFSA)
- ⑯ Cabinet, Bottom (GCABB3447AFSA)
- ⑰ Microphone Socket, SO101 (QSOCZ2468AFZZ)

**Figure 1 PARTS LAYOUT**



## GENERAL DESCRIPTION (Refer to Figure 2)

### RECEIVER SECTION

An input signal sent from the antenna is applied to the 1st-mixer (transistor Q2) via the RF amplifier (transistor Q1). Meanwhile, an oscillator signal delivered from the P.L.L. synthesizer is applied to the base of the transistor Q2 (1st-mixer) via the buffer circuit (transistor Q202). In this stage the above-mentioned input signal is converted to 1st-IF signal of 10.695 MHz.

This 1st-IF (10.695MHz) signal is supplied to the base of the transistor Q3 (2nd-mixer) through the transformers T3 and T4. Also to this transistor Q3 is supplied an oscillator signal (11.150MHz) from the transistor Q6, in which the signal is converted to 2nd-IF signal of 455kHz. The 2nd-IF (455kHz) signal is amplified by the 2nd-IF amplifier (transistors Q4 and Q5) and detected by the diode D2.

The output signal thus detected is applied to the terminal ⑥ of the integrated circuit IC-101 through the volume control (R705), amplified by the driver circuit and audio power amplifier circuit inside the IC-101 and finally applied to the speaker via the transformer T101.

### TRANSMITTER SECTION

An audio signal sent from the microphone is applied to the terminal ⑥ of the integrated circuit IC101 so that it be audio-amplified and then applied to the final-stage transistor Q304 and drive-stage transistor Q303 via the transformer T101. Meanwhile, a carrier signal synthesized by the P.L.L. synthesizer circuit is amplified by the 27MHz amplifier (transistors Q301 and Q302) and applied to the final-stage transistor Q304 through the drive-stage transistor Q303, in which it is modulated together with the aforesaid audio signal and finally transmitted through the antenna.

## DESCRIPTION OF PHASE-LOCKED-LOOP (P.L.L.) CIRCUIT (Refer to Figure 3)

### 1) What is P.L.L. ?

P.L.L. is abbreviation of Phase-Locked-Loop which synchronizes with frequency and phase of the stable standard input (crystal oscillation) given from the outside, namely working not only as automatic frequency control but also as automatic phase control.

The P.L.L. is now used to realize a synthesizer. Consisting of one crystal, the synthesizer serves as an oscillator to oscillate step by step (5kHz) in the receiver section range of 16.270MHz to 16.710MHz and the transmitter section range of 16.725 MHz to 17.165MHz.

Therefore, this synthesizer can be said to be on the same level in the connection with the accuracy and stability of oscillation as the crystal oscillator.

### 2) Frequency Synthesizer

The frequencies for both transmitter and receiver are synthesized by one crystal controlled oscillator and the Phase-Locked-Loop (or P.L.L.) consisting of eight basic building blocks: the divider (1/2) IC201, the divider (1/1024) IC201, the phase detector (phase comparator) IC201, the low-pass filter IC201, the voltage controlled oscillator (or V.C.O.) IC202, the down mixer IC202, the programmable divider IC201 and the tripler T201 as shown in Figure 3.

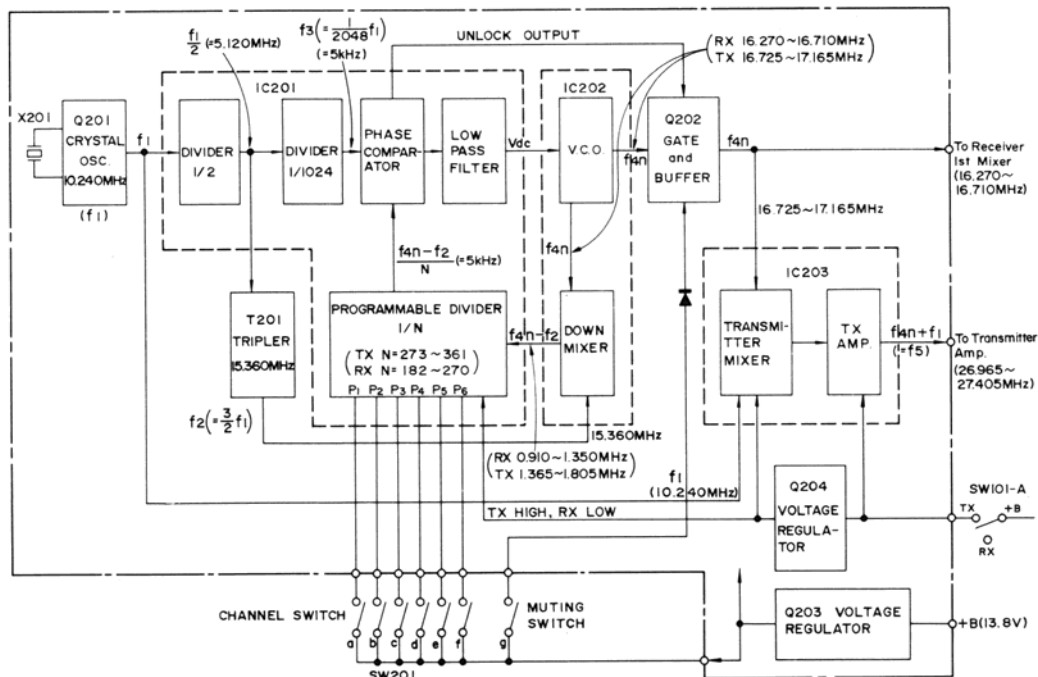

**Figure 3 P.L.L. CIRCUIT FREQUENCY SYNTHESIZER**

### 3) Frequency Determining (Refer to Figure 3 and Table 1)

- 1- The crystal oscillator consisting of a crystal X201 (10.240MHz) and transistor Q201 generates a basic frequency  $f_1$  (=10.240MHz).
- 2- The basic frequency  $f_1$  is applied to the fixed divided (1/2) network in the IC201 to be divided down to 5.120MHz signal (equivalent to 1/2 of the basic frequency  $f_1$ ). The 5.120MHz signal is further divided down to a 5kHz ( $f_3 = 1/2048 \cdot f_1$ ) signal by the fixed divided (1/1024) network and this frequency signal  $f_3$  (5kHz) is applied to the input of phase comparator.  
In addition to the above, the frequency signal  $f_1$  (10.240MHz) is also applied to the transmitter mixer inside the IC203 and the frequency signal  $f_1/2$  (5.120MHz) is converted to a signal  $f_2$  (15.360MHz) ( $f_2 = 3/2 \cdot f_1$ ) by the tripler network (transformer T201) and this frequency signal  $f_2$  is applied to the down mixer inside the IC202.
- 3- Frequency signal  $f_{4n}$  is the one that is generated by the voltage controlled oscillator (V.C.O.) inside the IC202 and this signal level is determined by DC voltage ( $V_{dc}$ ) coming from the IC201. This frequency signal  $f_{4n}$  is applied to the down mixer.  
The following will describe how the signal  $f_{4n}$  generated by the V.C.O. serves to make the P.L.L. (phase locked loop) circuit be locked.
- 4- The V.C.O. frequency signal  $f_{4n}$  is mixed down with the above-mentioned signal  $f_2$  (15.360MHz) by the down mixer inside the IC202, as a result of which there appears a mixed-down signal  $f_{4n} \cdot f_2$ . This frequency signal  $f_{4n} \cdot f_2$  is applied to the programmable divider inside the IC201.
- 5- The programmable divider (a portion of IC201) divides the frequency  $f_{4n} \cdot f_2$  by the frequency divider number  $N$  (Receiver 182 to 270, transmitter 273 to 361), which is programmable by the switch position of the channel selector connected to the terminal pins (11) to (16) of IC201. The assigned number is shown in Table 1. The output frequency  $(f_{4n} \cdot f_2) / N$  (near 5kHz) of the programmable divider is applied to another input of the phase comparator.
- 6- The phase comparator (IC201) compares the frequency  $f_3$  (=5kHz) and the other frequency  $(f_{4n} \cdot f_2) / N$  from the programmable divider and generates a DC voltage  $V_{dc}$  (voltage control signal) proportional to the phase differences of both frequencies. The signal  $V_{dc}$  moves downward when  $(f_{4n} \cdot f_2) / N$  goes higher than  $f_3$  and moves upward when  $(f_{4n} \cdot f_2) / N$  goes lower than  $f_3$ . When  $(f_{4n} \cdot f_2) / N$  equals to  $f_3$ , the  $V_{dc}$  does not move.  
The voltage signal  $V_{dc}$  from the output of phase comparator goes back to the V.C.O. (voltage controlled oscillator) IC202 via the low-pass filter. Then the closed feedback loop is established.
- 7- In this method, a closed-loop frequency-feedback system, which is so called P.L.L., is formed and the frequency  $f_{4n}$  of V.C.O. IC202 is locked.
- 8- When the P.L.L. is in lock, the two input signal frequencies to the phase comparator input are equal. Therefore the frequency  $f_{4n}$  is determined as follows:

#### The Receiver Frequency

$$f_{4n} = N \times f_3 + f_2$$

$$\text{where } f_2 = 15.360\text{MHz } (=3/2 \cdot f_1)$$

$$f_3 = 5\text{kHz } (=1/2048 \cdot f_1)$$

$$N = 182 \text{ to } 270 \dots \text{ Determined channel selector as shown in Table 1.}$$

For example, the frequency  $f_{4n}$  of "channel 1" is calculated as follows:

$$\begin{aligned} f_{4n} &= 182 \times 0.005 + 15.360 \text{ (MHz)} \\ &= 16.270 \text{ (MHz)} \end{aligned}$$

Namely " $N=182$ " is assigned for "channel 1" by channel selector. This frequency  $f_{4n}$  is applied to the first mixer Q2 of receiver and the mixer IC203 of transmitter through the buffer amplifier Q202 and the filter coils T205 and T206.

#### The Transmitter Frequency

$$(1) \quad f_{4n} = N \times f_3 + f_2$$

$$\text{where } f_2 = 15.360\text{MHz}$$

$$f_3 = 5\text{kHz}$$

$$N = 273 \text{ to } 361 \dots \text{ Determined by channel selector as shown Table 1.}$$

(During the transmission, switching signal becomes high level (DC) so that the frequency divider number  $N$  is changed from one to another and then the number will be applied to the programmable divider.)

For example, the frequency  $f_{4n}$  of "channel 1" is calculated as follows:

$$\begin{aligned} f_{4n} &= 273 \times 0.005 + 15.360 \text{ (MHz)} \\ &= 16.725 \text{ (MHz)} \end{aligned}$$

Namely " $N=273$ " is assigned for "channel 1" by channel selector.

This frequency  $f_{4n}$  is applied to the first mixer Q2 of receiver and the mixer IC203 of transmitter through the buffer amplifier Q202 and the filter coils T205 and T206.

(2) The transmitter frequency  $f_5$  is determined by mixing the frequency  $f_{4n}$  and the frequency  $f_1$  (= 10.240MHz).

$$f_5 = f_{4n} + f_1$$

$$= N \times f_3 + f_2 + f_1$$

$$\text{where } f_1 = 10.240\text{MHz}$$

$$f_2 = 15.360\text{MHz}$$

$$f_3 = 5\text{kHz}$$

$$N = 273 \text{ to } 361$$

For example, the frequency  $f_s$  of "channel 1" is calculated as follows:

$$f_s = 273 \times 0.005 + 15.360 + 10.240 \text{ (MHz)}$$

$$= 26.965 \text{ (MHz)}$$

Table 1 shows the synthesized frequencies for each channel.

- 9- The gate and buffer circuit made of transistor Q202 works to prevent emission of unnecessary waves when the P.L.L. circuit is unlocked or when one channel is changed over to another.
  - 10- The frequency divider number  $N$  of programmable divider is decided by the value set by either of the channel selector switches SW201-A (a ~ f). In any of the channels, it is designed that the frequency divider number  $N_T$  at the transmission is larger than that  $N_R$  at the reception by a difference of 91.
- $N_R = N_T - 91$

### FREQUENCY OF SYNTHESIS CHART

CHANNEL	$f_s$ (MHz)	$f_1$ (MHz)	$f_2 (=3/2f_1)$ (MHz)	$f_3 (=f_1/2048)$ (kHz)	RECEIVER					TRANSMITTER			
					N	$f_{4n}$ (MHz)	$f_{4n-f_2}$ (kHz)	$f_5-f_{4n}$ (= $f_6$ ) (MHz)	$f_7$ (MHz)	$f_7-f_6$ (= $f_8$ ) (kHz)	N	$f_{4n}$ (MHz)	$f_{4n-f_2}$ (kHz)
1	26.965	10.240	15.360	5	182	16.270	910	10.695	11.150	455	273	16.725	1365
2	26.975	10.240	15.360	5	184	16.280	920	10.695	11.150	455	275	16.735	1375
3	26.985	10.240	15.360	5	186	16.290	930	10.695	11.150	455	277	16.745	1385
4	27.005	10.240	15.360	5	190	16.310	950	10.695	11.150	455	281	16.765	1405
5	27.015	10.240	15.360	5	192	16.320	960	10.695	11.150	455	283	16.775	1415
6	27.025	10.240	15.360	5	194	16.330	970	10.695	11.150	455	285	16.785	1425
7	27.035	10.240	15.360	5	196	16.340	980	10.695	11.150	455	287	16.795	1435
8	27.055	10.240	15.360	5	200	16.360	1000	10.695	11.150	455	291	16.815	1455
9	27.065	10.240	15.360	5	202	16.370	1010	10.695	11.150	455	293	16.825	1465
10	27.075	10.240	15.360	5	204	16.380	1020	10.695	11.150	455	295	16.835	1475
11	27.085	10.240	15.360	5	206	16.390	1030	10.695	11.150	455	297	16.845	1485
12	27.105	10.240	15.360	5	210	16.410	1050	10.695	11.150	455	301	16.865	1505
13	27.115	10.240	15.360	5	212	16.420	1060	10.695	11.150	455	303	16.875	1515
14	27.125	10.240	15.360	5	214	16.430	1070	10.695	11.150	455	305	16.885	1525
15	27.135	10.240	15.360	5	216	16.440	1080	10.695	11.150	455	307	16.895	1535
16	27.155	10.240	15.360	5	220	16.460	1100	10.695	11.150	455	311	16.915	1555
17	27.165	10.240	15.360	5	222	16.470	1110	10.695	11.150	455	313	16.925	1565
18	27.175	10.240	15.360	5	224	16.480	1120	10.695	11.150	455	315	16.935	1575
19	27.185	10.240	15.360	5	226	16.490	1130	10.695	11.150	455	317	16.945	1585
20	27.205	10.240	15.360	5	230	16.510	1150	10.695	11.150	455	321	16.965	1605
21	27.215	10.240	15.360	5	232	16.520	1160	10.695	11.150	455	323	16.975	1615
22	27.225	10.240	15.360	5	234	16.530	1170	10.695	11.150	455	325	16.985	1625
23	27.255	10.240	15.360	5	240	16.560	1200	10.695	11.150	455	331	17.015	1655
24	27.235	10.240	15.360	5	236	16.540	1180	10.695	11.150	455	327	16.995	1635
25	27.245	10.240	15.360	5	238	16.550	1190	10.695	11.150	455	329	17.005	1645
26	27.265	10.240	15.360	5	242	16.570	1210	10.695	11.150	455	333	17.025	1665
27	27.275	10.240	15.360	5	244	16.580	1220	10.695	11.150	455	335	17.035	1675
28	27.285	10.240	15.360	5	246	16.590	1230	10.695	11.150	455	337	17.045	1685
29	27.295	10.240	15.360	5	248	16.600	1240	10.695	11.150	455	339	17.055	1695
30	27.305	10.240	15.360	5	250	16.610	1250	10.695	11.150	455	341	17.065	1705
31	27.315	10.240	15.360	5	252	16.620	1260	10.695	11.150	455	343	17.075	1715
32	27.325	10.240	15.360	5	254	16.630	1270	10.695	11.150	455	345	17.085	1725
33	27.335	10.240	15.360	5	256	16.640	1280	10.695	11.150	455	347	17.095	1735
34	27.345	10.240	15.360	5	258	16.650	1290	10.695	11.150	455	349	17.105	1745
35	27.355	10.240	15.360	5	260	16.660	1300	10.695	11.150	455	351	17.115	1755
36	27.365	10.240	15.360	5	262	16.670	1310	10.695	11.150	455	353	17.125	1765
37	27.375	10.240	15.360	5	264	16.680	1320	10.695	11.150	455	355	17.135	1775
38	27.385	10.240	15.360	5	266	16.690	1330	10.695	11.150	455	357	17.145	1785
39	27.395	10.240	15.360	5	268	16.700	1340	10.695	11.150	455	359	17.155	1795
40	27.405	10.240	15.360	5	270	16.710	1350	10.695	11.150	455	361	17.165	1805

**CRYSTAL**

- X1 crystal      11.150MHz =  $f_7$
- X201 crystal    10.240MHz =  $f_1$

Table 1 FREQUENCY OF SYNTHESIS CHART

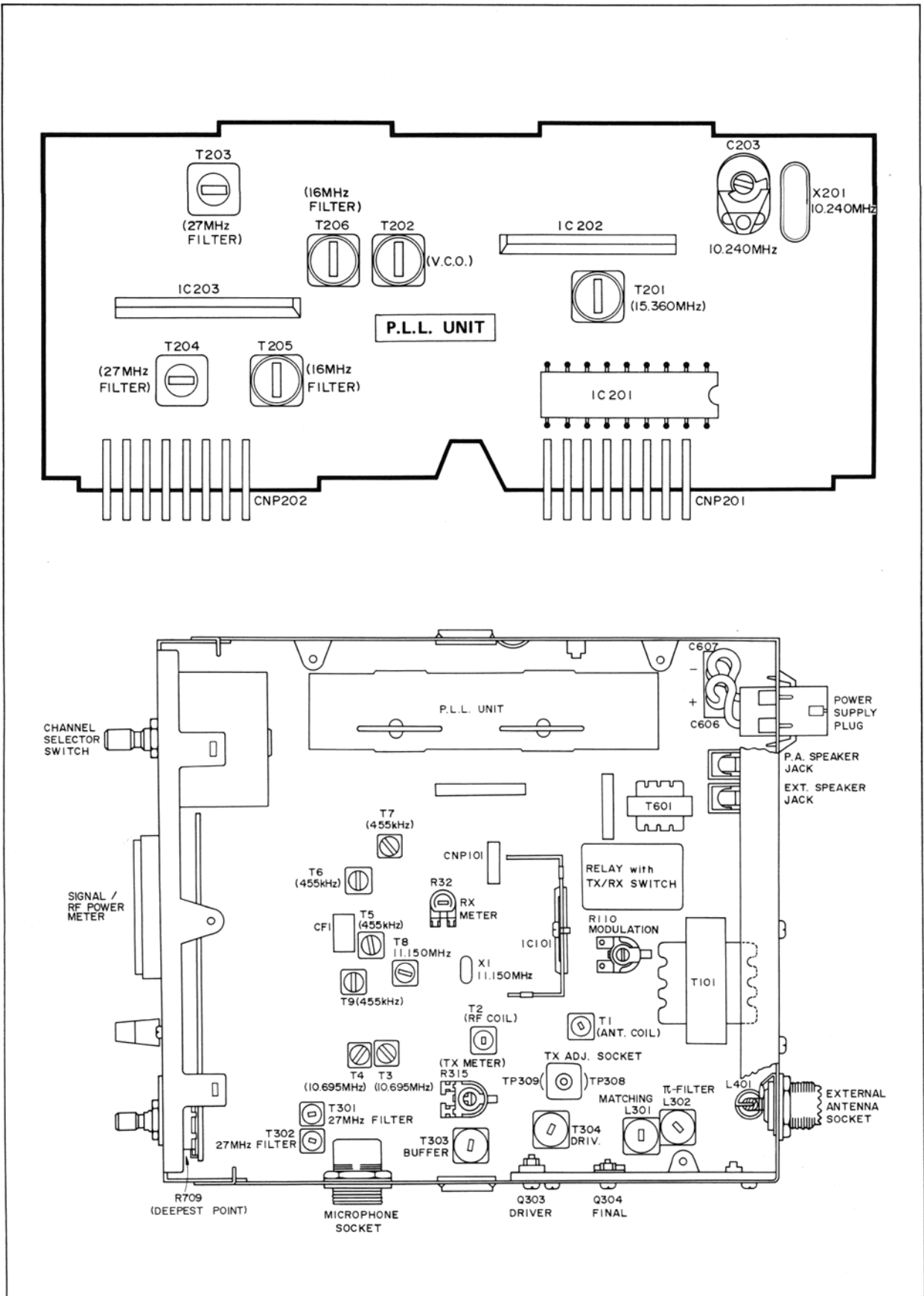

Figure 4 ALIGNMENT POINTS

## ALIGNMENT

### EQUIPMENT REQUIRED

Frequency Counter:	0 to 40MHz (High Sensitivity)	DC V.T.V.M.:	0 to 10V
Synchroscope:	0 to 50MHz	DC Milliammeter:	0 to 500mA with Low-pass Filter
Signal Generator:	10MHz to 30MHz with 1000Hz AM mod.	Dummy Load 8 ohms and 50 ohms:	Non-inductive
Audio Signal Generator:	1000Hz (sine wave)	Spectrum Analyzer or Field Strength Meter	
Audio Attenuator:	0 to 100dB	CM Coupler	
RF Output Power Meter:	0 to 5W at 27MHz	DC Power Supply:	13.8V, 2A
RF Voltmeter:	0 to 3V, 0 to 50MHz		
AC V.T.V.M.:	0 to 10V		

### [NOTE]

- 1- Keep supply voltage to 13.8V always during the alignment.
- 2- The tools to be used for the alignment should be non-metallic ones.
- 3- Be sure to keep 50 ohms dummy load connectable with the antenna terminal all the way during the transmitter alignment.
- 4- As to the alignment of the modulation circuit, be sure to use the microphone plug shown in Figure 5 to be connected to it.

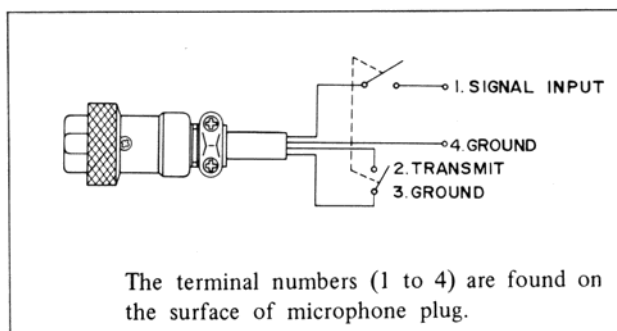

**Figure 5 CONNECTION OF MICROPHONE PLUG**

### PHASE LOCKED LOOP (P.L.L.) CIRCUIT ALIGNMENT

STEP	CONNECTION OF MEASURING INSTRUMENT	ADJUSTMENT	PROCEDURE
1 (10.240 MHz)	Connect a frequency counter, through 5PF capacitor, to the test point <b>TP201</b> (Emitter of transistor Q201).	C203	Adjust so that the frequency counter reads within 10.240 MHz $\pm$ 300 Hz.
2 (15.360 MHz)	1) Connect an RF voltmeter to the test point <b>TP202</b> (the terminal No. 4 of IC 202). 2) Connect a frequency counter, through 5PF capacitor, to the test point <b>TP202</b> .	T201	1) Adjust so that the RF voltmeter reads the maximum. 2) Make sure the frequency counter is reading within 15.360 MHz $\pm$ 450 Hz.
3 (V.C.O.)	Connect a D.C. V.T.V.M. to the test point <b>TP203</b> .	T202	1) Set the channel selector to "1" channel. 2) Adjust so that the D.C. V.T.V.M. reads exactly 2.0V. 3) Set in turn the channel selector to "1" channel and/or "40" channel and make sure the D.C. V.T.V.M. reads within 2.0V to 4.3V.
RX	4 (16MHz Filter)	T205 T206	1) Set the channel selector to "40" channel. 2) Adjust so that the RF voltmeter reads the maximum. (about 400mV $\pm$ 200mV)
	5 (16MHz Frequency)	---	1) Set the channel selector to "1" channel. 2) Make sure the frequency counter is reading 16.270 MHz. 3) Set the channel selector to "40" channel. 4) Make sure the frequency counter is reading 16.710 MHz.
TX	6 (27MHz Filter)	T203 T204	1) Set the channel selector to "20" channel. 2) Adjust so that the RF voltmeter reads the maximum. (about 2.5V to 3.5V)
	7 (27MHz Frequency)	---	1) Set the channel selector to "20" channel. 2) Make sure the frequency counter is reading within 27.205 MHz $\pm$ 300 Hz.

## RECEIVER ALIGNMENT

STEP	CONNECTION OF MEASURING INSTRUMENT	ADJUSTMENT	PROCEDURE
1 (11.150 MHz)	Connect a frequency counter, through 5PF capacitor, to the test point [TP1] . (Base of transistor Q3)	T8	1) Set the delta tuning switch to "0" position. 2) Adjust so that the frequency counter reads within 11.150 MHz $\pm$ 100 Hz. (The oscillation voltage then is about 60 mV to 80 mV)
2 (1st-IF and 2nd-IF)	1) Connect an AC V.T.V.M. to both sides of the speaker voice coil lug. 2) Connect a signal generator, through 0.01 MFD capacitor, to the test point [TP2] (the secondary of the transformer T2). 3) Set the signal generator to 10.695 MHz, modulation 1000 Hz, 30% . NOTE: Be sure to connect the ground wire of signal generator to the ground of the external antenna socket.	T3 T4 T5 T6 T7 T9	Adjust so that the AC V.T.V.M. reads the maximum. 
3 (RF)	1) Connect the AC V.T.V.M. to both sides of the speaker voice coil lug. 2) Connect the signal generator to the external antenna socket. 3) Set the signal generator to 27.175 MHz (18 channel), modulation 1000 Hz, 30% .	T2 T1	1) Set the channel selector to "18" channel. 2) Adjust the AC V.T.V.M. until it reads the maximum.
4 (Deepest Point of Squelch)	1) Connect a signal generator to the external antenna socket, keeping the frequency of signal generator to 27.175 MHz ("18 channel") and modulation 1000Hz, 30%. 2) Connect a low-frequency wattmeter to the external speaker jack.	R709 (5Kohms -B)	1) Set the channel selector of the unit to "18 channel" and the volume control to "maximum". 2) Adjust the output level of signal generator to "40dB". At the time make sure the output signal is maximum (about 4W). 3) Rotate the squelch control knob of the unit fully clockwise. 4) Adjust the semi-fixed resistor R709 so that the low-frequency output becomes 0.5W.

## TRANSMITTER AND MODULATOR ALIGNMENT

- 1- When the set is made ready for the transmitting operation, be sure to always connect the RF output power meter and 50 ohms dummy load to the external antenna socket--this should never be forgotten even if it is not noted down specifically. If otherwise, the final transistor Q304 may be damaged.
- 2- When making the connection of measuring instruments, see Figure 6.

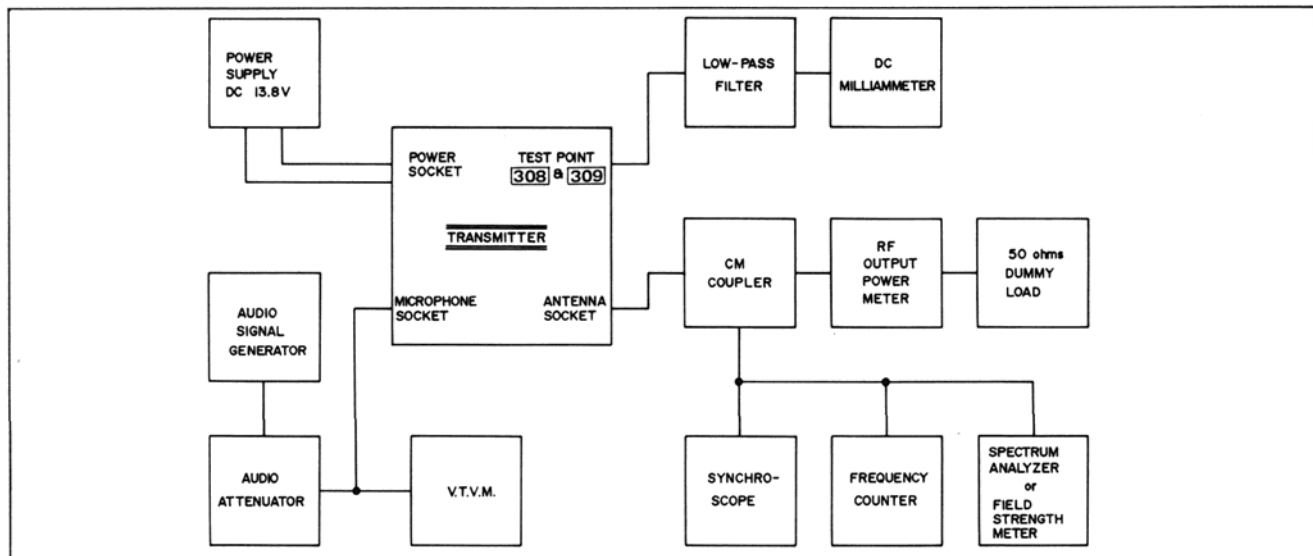

Figure 6

STEP	CONNECTION OF MEASURING INSTRUMENT	ADJUSTMENT	PROCEDURE
1 (27 MHz Filter)	Connect the synchroscope to the test point <b>TP301</b> (Base of transistor Q302).	T301 T302	1) Set the channel selector to "20" channel. 2) Adjust so that the maximum waveform (amplitude) appears on the synchroscope. 3) Set in turn the channel selector to "1" channel and/or "40" channel to make sure the waveform doesn't decrease in size.
2 (Buffer)	1) Remove the plug which have been inserted in the test points <b>TP308</b> and <b>TP309</b> of the set. 2) Connect in turn DC milliammeter, through the RF rejection filter shown in Figure 7, to the test points <b>TP308</b> and <b>TP309</b> .	T303	1) Set the channel selector to "20" channel. 2) Adjust so that the DC milliammeter connected to the test point <b>TP309</b> , reads the maximum. (Driver current)
3 (Driver)	Same as above.	T304	Adjust so that the DC milliammeter connected to the test point <b>TP309</b> indicates the dip point. The amperage then is about 45 to 80mA.
4 (Final)	Same as step 2, and connect the RF output power meter and 50 ohms dummy load to the external antenna socket.	L301	Adjust so that the DC milliammeter connected to the test point <b>TP308</b> reads 450mA $\pm$ 50mA (Final current).
5 ( $\pi$ -Filter)	Same as above.	L302	Adjust so that the RF output power meter reads the maximum. The reading then should not exceed 4W. (FCC Rules and Regulations Part 95, Section 95. 43.)
6	Repeat the steps 2 to 5 until the best results will be obtained.		
7 (Modulation)	1) Connect the RF output power meter, 50 ohms dummy load and synchroscope, through CM coupler, to the external antenna socket. 2) Connect a audio signal generator, attenuator and AC V.T.V.M. to the microphone socket (using the microphone plug shown in Figure 5). 3) Keep the output of audio signal generator to 1000 Hz, 700mV.	R110 (1Kohms -B)	1) Turn R110 counterclockwise until the modulation limiter circuit stops its function. 2) Make sure there appears 700mV input signal at the microphone terminal from an audio signal generator. 3) Adjust R110 so that the modulation factor of RF output waveform appeared on the synchroscope becomes 95 to 99% (See Figure 8). 4) Set the attenuator to "-41dB" (6 mV). 5) Make sure the modulation factor of RF output waveform on a synchroscope is more than 50%.

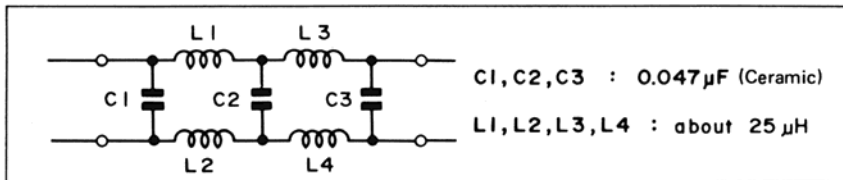

Figure 7 RF REJECTION FILTER  
(LOW-PASS FILTER)

**SIGNAL/RF POWER METER ADJUSTMENT**

STEP	CONNECTION OF MEASURING INSTRUMENT	ADJUSTMENT	PROCEDURE
1 (RX)	Connect the signal generator to the antenna socket and set the frequency to 27.175 MHz ("18" channel) and the modulation to 1000Hz, 30%. Keep the output of signal generator to 40dB.	R32	1) Set the channel selector to "18" channel. 2) Adjust so that the signal/RF power meter indicates "9" on the "SIGNAL" scale.
2 (TX)	Connect the RF output power meter and 50 ohms dummy load to the antenna socket.	R315	1) Set the channel selector to "20" channel and make the set be ready for the transmitting operation (non-modulation however). 2) First make sure of what value the pointer of signal/RF power meter indicates on the "POWER" scale and then adjust R315 so that such a value becomes nearly the same as that of the RF output power meter connected to the antenna socket. (The RF power output then is about 3.5W.)

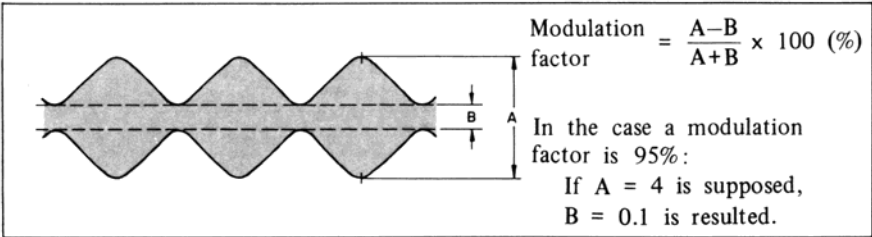

Figure 8

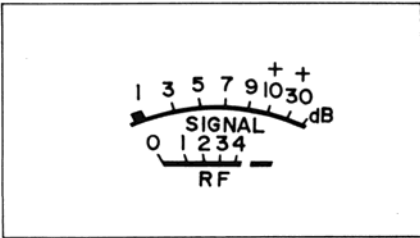

Figure 9 SIGNAL/RF POWER METER (ME701)

## CHANNEL SELECTOR SWITCH

Connection table of channel selector switch (SW201) for each channel.

CHANNEL	TERMINAL NO. OF THE SW201A (14)	(Po)	1 (P1)	2 (P2)	3 (P3)	4 (P4)	5 (P5)	6 (P6)	8
CHANNEL	TERMINAL NO. OF IC201	-	16	15	14	13	12	11	-
1									●
2			○						●
3				○					●
4					○				●
5			○		○				
6				○	○				
7			○	○	○				
8			○			○			●
9				○		○			●
10			○	○		○			●
11					○	○			●
12				○	○	○			
13			○	○	○	○			
14							○		●
15			○				○		
16			○	○			○		●
17					○		○		●
18			○		○		○		●
19				○	○		○		●
20						○	○		●
21			○			○	○		●
22				○		○	○		●
23			○	○	○	○	○		●
24			○	○		○	○		●
25					○	○	○		●
26				○	○	○	○		●
27			○	○	○	○	○		●
28								○	●
29			○					○	●
30				○				○	●
31			○	○				○	●
32					○			○	●
33			○		○			○	●
34				○	○			○	●
35			○	○	○			○	●
36						○		○	●
37			○			○		○	●
38				○		○		○	●
39			○	○		○		○	●
40					○	○		○	●

**NOTES:**

1. Terminals marked ○ are connected with the terminal C1.
2. Terminals marked ◎ are connected with the terminal C2.
3. The mark ● given on the terminal No. 8 of SW201 shows that this terminal comes in contact with the COMMON terminal if the set gets in a channel-to-channel situation.

QSW-R0144AFZZ

VIEW FROM TERMINAL  
INSERTION SIDE

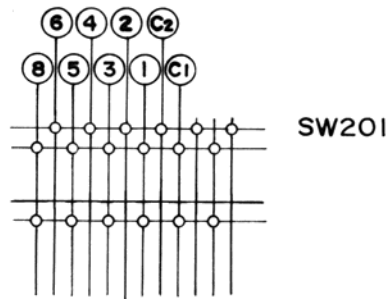

MOUNTING BASE

Table 2 CHANNEL SELECTOR SWITCH

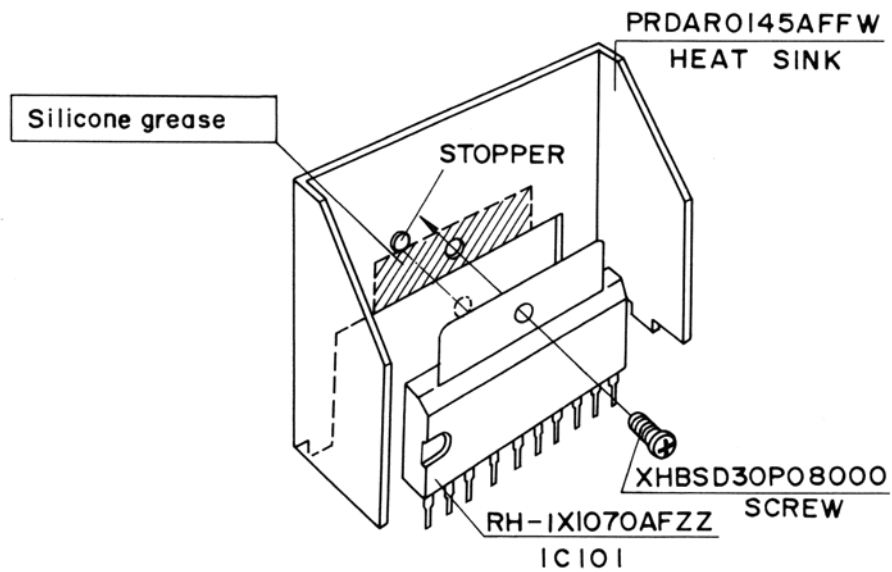
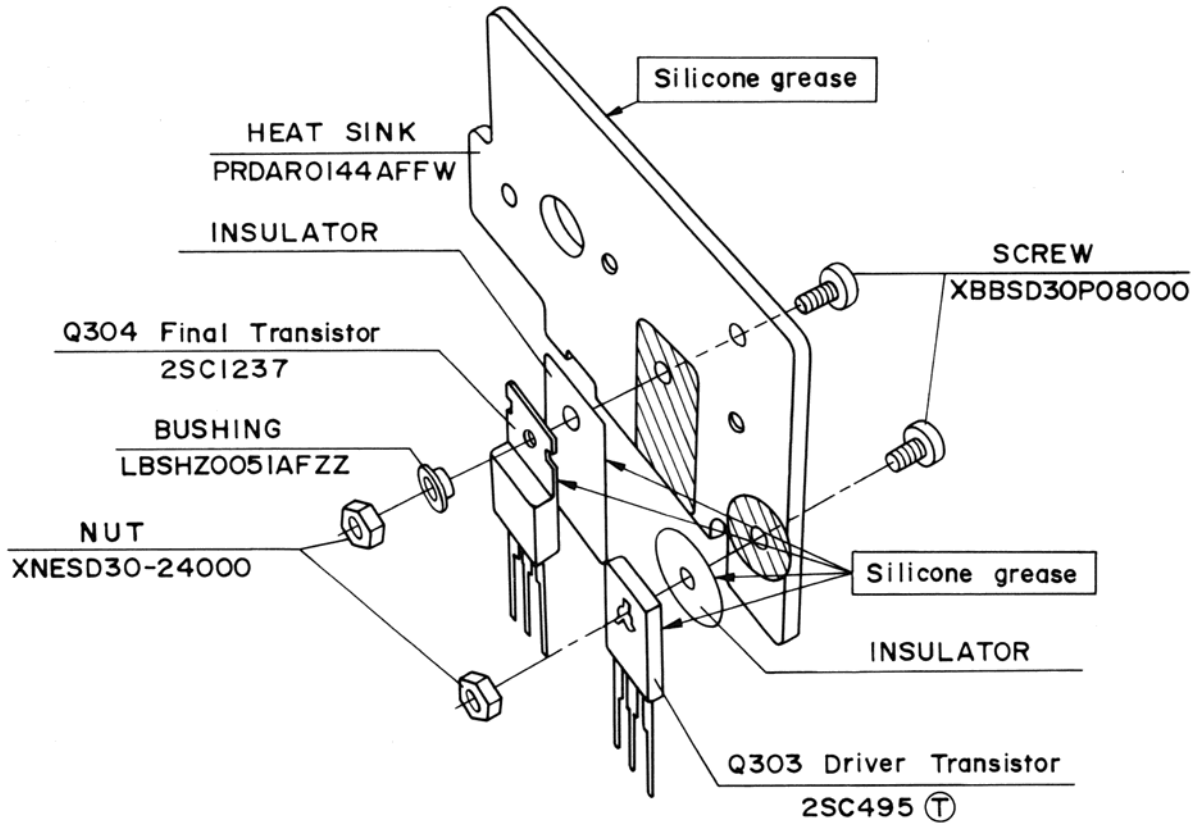

Figure 10 HOW TO SET THE TRANSISTORS AND IC

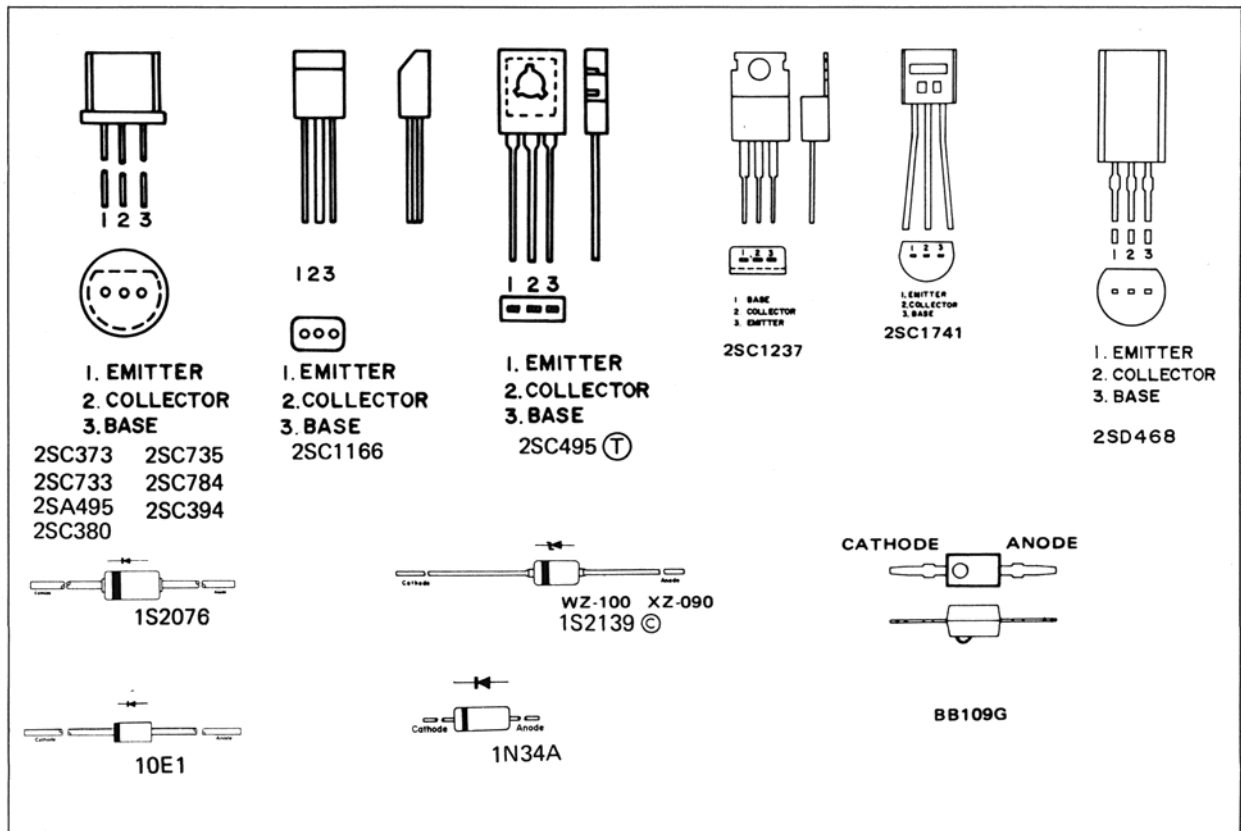

Figure 11 SEMICONDUCTORS BASING

# REPLACEMENT PARTS LIST

## "HOW TO ORDER REPLACEMENT PARTS"

To have your order filled promptly and correctly, please furnish the following informations.

1. MODEL NUMBER
2. REF. NO.
3. PART NO.
4. DESCRIPTION

Order to : Parts Center

P.O. Box 664 Paramus, New Jersey 07652 (201) 265-5600

P.O. Box 20394 Long Beach, Calif. 90801 (213) 830-4470

REF. NO.	PART NO.	DESCRIPTION	PRICE	REF. NO.	PART NO.	DESCRIPTION	PRICE
<b>INTEGRATED CIRCUITS</b>				D1	VHD1S2076//-1	Static Protector (1S2076)	
IC101	RH-IX1070AFZZ	Audio Power Amplifier (TA7205AP)		D2	VHD1N34A///-1	Detector (1N34A)	
IC201	RH-IX1067AFZZ	P.L.L. Synthesizer, Divider, Phase Comparator, Low-Pass Filter and Programmable Divider (TC9102P)		D4	VHD1S2076//-1	A.N.L. (Automatic Noise Limiter) (1S2076)	
IC202	RH-IX1068AFZZ	P.L.L. Synthesizer, V.C.O. (Voltage Controlled Oscillator) and Down Mixer (TA7310P)		D5	VHEWZ-100//1F	Zener Diode, Voltage Regulator (10V±0.5V) (WZ-100)	
IC203	RH-IX1068AFZZ	Transmitter, 27MHz Mixer and Amplifier (TA7310P)		D6	VHD1N34A///-1	Squelch (1N34A)	
<b>TRANSISTORS</b>				D7	VHD1N34A///-1	Squelch (1N34A)	
Q1	VS2SC784-R/1F	RF Amplifier (2SC784®)		D8	VHD1N34A///-1	A.V.C. (1N34A)	
Q2	VS2SC394-Y/-1	1st-Mixer (10.695MHz) (2SC394 Y)		D101	VHD1S2076//-1	Modulation Limiter (1S2076)	
Q3	VS2SC380-O/-1	2nd-Mixer (455kHz) (2SC380 O)		D102	VHD1S2076//-1	Modulation Limiter (1S2076)	
Q4	VS2SC380-Y/-1	IF (455kHz) Amplifier (2SC380 Y)		D201	VHCBB109G//-1	Varicap, V.C.O. (BB109G)	
Q5	VS2SC380-Y/-1	IF (455kHz) Amplifier (2SC380 Y)		D202	VHC1S2139-C-1	Varicap, TX Shifter (1S2139 C)	
Q6	VS2SC380-O/-1	Crystal (11.150MHz) Oscillator (2SC380 O)		D203	VHD1S2076//-1	Switching (1S2076)	
Q7	VS2SC373-G/-1	AVC Amplifier (2SC373)		D204	VHEXZ-090//-1	Zener Diode, Voltage Regulator, 9V±0.25V (XZ-090)	
Q8	VS2SC733-BL-1	Squelch Voltage Amplifier (2SC733 BL)		D205	VHEXZ-090//-1	Zener Diode, Voltage Regulator, 9V±0.25V (XZ-090)	
Q101	VS2SA495-Y/-1	Modulation Limiter (2SA495 Y)		D301	VHD1S2076//-1	Static Protector (1S2076)	
Q201	VS2SC373-G/-1	P.L.L. Synthesizer, Crystal (10.240MHz) Oscillator (2SC373)		D302	VHD1S2076//-1	Static Protector (1S2076)	
Q202	VS2SC373-G/-1	P.L.L. Synthesizer, Buffer and Gate (2SC373)		D303	VHD1S2076//-1	Meter, RF Power (1S2076)	
Q203	VS2SD468-C/-1	P.L.L. Synthesizer, Voltage Regulator (2SD468 C)		D601	VHD10E1////-1	Circuit Protector (10E1)	
Q204	VS2SC1741//1	P.L.L. Synthesizer, Voltage Regulator, TX (2SC1741)		D602	VHD10E1////-1	Protector (10E1)	
Q301	VS2SC735-Y/-1	Transmitter, Buffer Amplifier (2SC735 Y)		D701	VHD1S2076//-1	Squelch (1S2076)	
Q302	VS2SC1166-Y-1	Transmitter, 27MHz Amplifier (2SC1166 Y)		<b>COILS</b>			
Q303	VS2SC495-T/-1	Transmitter, Driver (2SC495 T)		L101	RCILC0023AFZZ	AF Choke	
Q304	VS2SC1237-1F	Transmitter, Final (2SC1237)		L102	RCILC0059AFZZ	RF Choke	
<b>DIODES</b>				L103	RCILC0059AFZZ	RF Choke	
				L301	RCILR0135AFZZ	Transmitter, Matching (Loading)	
				L302	RCILR0055AFZZ	Transmitter, π-Filter	
				L305	RCILC0011AFZZ	RF Choke (TX)	
				L401	RCILR0329AFZZ	Antenna Choke	
<b>TRANSFORMERS</b>				<b>TRANSFORMERS</b>			
				T1	RCILA0412AFZZ	Antenna	
				T2	RCILR0304AFZZ	RF	
				T3	RCIL10157AFZZ	1st-IF (10.695MHz)	
				T4	RCIL10157AFZZ	1st-IF (10.695MHz)	
				T5	RCIL10228AFZZ	2nd-IF (455kHz)	
				T6	RCIL10229AFZZ	2nd-IF (455kHz)	
				T7	RCIL10169AFZZ	2nd-IF (455kHz)	
				T8	RCILB0421AFZZ	2nd Local Oscillator (11.150MHz)	
				T9	RCIL10228AFZZ	2nd-IF (455kHz)	
				T101	RTRNM0050AFZZ	Output and Modulation	
				T201	RCILR3242AAZZ	Tripler (15.360MHz)	



# PARTS LIST

REF. NO.	PART NO.	DESCRIPTION	PRICE	REF. NO.	PART NO.	DESCRIPTION	PRICE
C221	VCCSPU1HL101J	100PF, 50V, ±5%, Ceramic		C604	VCKZPU1HF333P	.033MFD, 50V, +100 -0%, Ceramic	
C222	VCKYPU1HB102M	.001MFD, 50V, ±20%, Ceramic		C605	VCKZPU1HF333P	.033MFD, 50V, +100 -0%, Ceramic	
C223	VCQYKU1HM223M	.022MFD, 50V, ±20%, Mylar		C608	VCKZPU1HF103Z	.01MFD	
C224	VCCSPU1HL101J	100PF, 50V, ±5%, Ceramic		C701	VCQYKU1HM333M	.033MFD, 50V, ±20%, Mylar	
C226	VCCCPU1HH330J	33PF (CH), 50V, ±5%, Ceramic		C702	VCQYKU1HM223M	.022MFD, 50V, ±20%, Mylar	
C227	VCKZPU1HF103Z	.01MFD		C703	VCCSPU1HL220J	22PF, 50V, ±5%, Ceramic	
C229	VCKZPU1HF103Z	.01MFD		C704	VCCSPU1HL560J	56PF, 50V, ±5%, Ceramic	
C230	VCCCPU1HH100F	10PF (CH), 50V, ±1PF, Ceramic		C705	VCQYKU1HM332M	.0033MFD, 50V, ±20%, Mylar	
C231	VCKZPU1HF103Z	.01MFD					
C233	VCCRPUI1HH390J	39PF (RH), 50V, ±5%, Ceramic					
C234	VCKZPU1HF103Z	.01MFD					
C235	VCCRPUI1HH330J	33PF (RH), 50V, ±5%, Ceramic					
C236	VCKZPU1HF103Z	.01MFD					
C238	VCKYPU1HB102M	.001MFD, 50V, ±20%, Ceramic					
C239	VCCSPU1HL820J	82PF, 50V, ±5%, Ceramic					
C240	VCCSPU1HL101J	100PF, 50V, ±5%, Ceramic					
C241	VCCSPU1HL101J	100PF, 50V, ±5%, Ceramic					
C243	VCCSPU1HL151J	150PF, 50V, ±5%, Ceramic					
C245	VCQYKU1HM103M	.01MFD, 50V, ±20%, Mylar					
C301	VCCSPU1HL330J	33PF, 50V, ±5%, Ceramic					
C302	VCCSPU1HL390J	39PF, 50V, ±5%, Ceramic					
C303	VCCSPU1HL390J	39PF, 50V, ±5%, Ceramic					
C304	VCCSPU1HL3R0C	3PF, 50V, ±0.25PF, Ceramic					
C305	VCKZPU1HF103Z	.01MFD					
C306	VCKZPU1HF103Z	.01MFD					
C307	VCCSPU1HL151J	150PF, 50V, ±5%, Ceramic					
C308	VCCSPU1HL4R0C	4PF, 50V, ±0.25PF, Ceramic					
C309	VCKZPU1HF103Z	.01MFD					
C310	VCCSPU1HL100D	10PF, 50V, ±0.5PF, Ceramic					
C311	VCKZPU1HF103Z	.01MFD					
C312	VCCSPU1HL221J	220PF, 50V, ±5%, Ceramic					
C313	VCCSPU1HL471J	470PF, 50V, ±5%, Ceramic					
C314	VCKYPU1SD103Z	.01MFD (Z5T), 30V, +80 -20%, Ceramic					
C315	VCCSPU1HL511J	510PF, 50V, ±5%, Ceramic					
C316	VCCSPU1HL180J	18PF, 50V, ±5%, Ceramic					
C317	VCKYPU1SD103Z	.01MFD (Z5T), 30V, +80 -20%, Ceramic					
C318	VCKYPU1SD103Z	.01MFD (Z5T), 30V, +80 -20%, Ceramic					
C319	VCKYPU1SD103Z	.01MFD (Z5T), 30V, +80 -20%, Ceramic					
C320	VCCSPU1HL511J	510PF, 50V, ±5%, Ceramic					
C321	VCCSPU1HL331J	330PF, 50V, ±5%, Ceramic					
C322	VCKYPU1SD103Z	.01MFD (Z5T), 30V, +80 -20%, Ceramic					
C323	VCCSPU1HL181J	180PF, 50V, ±5%, Ceramic					
C324	VCCSPU1HL271J	270PF, 50V, ±5%, Ceramic					
C325	VCCSPU1HL391J	390PF, 50V, ±5%, Ceramic					
C326	VCCSPU1HL150J	15PF, 50V, ±5%, Ceramic					
C327	VCKZPU1HF103Z	.01MFD					
C330	VCKYPU1SD103Z	.01MFD (Z5T), 30V, +80 -20%, Ceramic					
C331	VCKZPU1HF103Z	.01MFD					
C333	VCCSPU1HL511J	510PF, 50V, ±5%, Ceramic					
C334	VCKZPU1HF103Z	.01MFD					
C335	VCCSPU1HL511J	510PF, 50V, ±5%, Ceramic					
C336	VCCSPU1HL330J	33PF, 50V, ±5%, Ceramic					
C401	VCCSPU1HL151J	150PF, 50V, ±5%, Ceramic					
C402	VCKYPU1SD103Z	.01MFD (Z5T), 30V, +80 -20%, Ceramic					
C601	VCKZPU1HF103Z	.01MFD					

### RESISTORS

(Unless otherwise specified resistors are 1/4W, ±5%, Carbon Type).

R1	VRD-ST2EE472J	4.7K ohm
R2	VRD-ST2EE152J	1.5K ohm
R3	VRD-ST2EE102J	1K ohm
R4	VRD-ST2EE222J	2.2K ohm
R5	VRD-ST2EE473J	47K ohm
R6	VRD-ST2EE562J	5.6K ohm
R7	VRD-ST2EE471J	470 ohm
R8	VRD-ST2EE472J	4.7K ohm
R9	VRD-ST2EE333J	33K ohm
R10	VRD-ST2EE681J	680 ohm
R12	VRD-SU2EY223J	22K ohm
R13	VRD-ST2EE472J	4.7K ohm
R14	VRD-ST2EE102J	1K ohm
R15	VRD-ST2EE273J	27K ohm
R16	VRD-SU2EY562J	5.6K ohm
R17	VRD-SU2EY102J	1K ohm
R18	VRD-SU2EY102J	1K ohm
R20	VRD-SU2EY224J	220K ohm
R21	VRD-SU2EY333J	33K ohm
R22	VRD-SU2EY223J	22K ohm
R23	VRD-ST2EE333J	33K ohm
R24	VRD-ST2EE153J	15K ohm
R27	VRD-SU2EY104J	100K ohm
R28	VRD-SU2EY224J	220K ohm
R29	VRD-SU2EY104J	100K ohm
R30	VRD-SU2BY333J	33K ohm, 1/8W, ±5%, Carbon
R31	VRD-SU2EY154J	150K ohm
R32	RVR-M0146AFZZ	30K (B) ohm, Signal Meter Adjust
R34	VRD-ST2EE222J	2.2K ohm
R35	VRD-SU2EY222J	2.2K ohm
R36	VRD-ST2EE223J	22K ohm
R37	VRD-ST2EE472J	4.7K ohm
R38	VRD-ST2EE151J	150 ohm
R39	VRD-ST2EE101J	100 ohm
R40	VRD-SU2EY823J	82K ohm
R41	VRD-ST2EE471J	470 ohm
R42	VRD-ST2EY824J	820K ohm
R101	VRD-ST2EE153J	15K ohm
R102	VRD-ST2EE222J	2.2K ohm
R103	VRD-ST2EE470J	47 ohm
R106	VRD-ST2EE222J	2.2K ohm
R107	VRD-ST2EE222J	2.2K ohm
R108	VRD-ST2EE223J	22K ohm
R109	VRD-ST2EE153J	15K ohm
R110	RVR-M0123AFZZ	1K (B) ohm, Modulation Level Adjust

# PARTS LIST

REF. NO.	PART NO.	DESCRIPTION	PRICE	REF. NO.	PART NO.	DESCRIPTION	PRICE
R111	VRD-ST2EE392J	3.9K ohm		<b>MISCELLANEOUS</b>			
R112	VRD-SU2EY563J	56K ohm		GCABA3447AFSA	Cabinet, Top		
R140	VRD-ST2HA1R0K	1 ohm, 1/2W, ±10%, Carbon		GCABB3447AFSA	Cabinet, Bottom (Speaker Side)		
R201	VRD-SS2EY563J	56K ohm		HBDGS3050AFSA	Decoration Plate, 40 CHANNEL		
R202	VRD-SS2EY473J	47K ohm		HDALP0369AFSA	Dial, Channel		
R203	VRD-SS2EY152J	1.5K ohm		HINDM1080AFSB	Emblem "SHARP"		
R205	VRD-SS2EY222J	2.2K ohm		HINDI0056AFSA	Indication, Channel, Acryl, White		
R206	VRD-SS2EY103J	10K ohm		HPNLC1227AFSA	Front Panel		
R207	VRD-SS2EY562J	5.6K ohm		JKNBM0219AFSA	Knob, ANL Switch, Delta Tuning Switch		
R208	VRD-SS2EY103J	10K ohm		JKNBN0337AFSA	Knob, Channel Selector		
R209	VRD-SS2EY224J	220K ohm		JKNBN0300AFSA	Knob, Off/Volume Control, Squelch Control/P.A. Switch		
R210	VRD-SS2EY103J	10K ohm		LANGF0407AFFW	Bracket, Output/Modulation Transformer, Small		
R211	VRD-SS2EY102J	1K ohm		LANGR0418AFFW	Bracket, Output/Modulation Transformer, Large		
R212	VRD-SS2EY103J	10K ohm		LBRC-0051AFSA	Mobile Mounting Bracket		
R214	VRD-SS2EY561J	560 ohm		LBSHZ0051AFZZ	Bushing, Transistor Q304		
R215	VRD-SS2EY222J	2.2K ohm		LCHSS0121AFFW	Chassis, Front		
R216	VRD-SS2EY331J	330 ohm		LCHSM2082AAZZ	Bracket, P.L.L. Circuit P.W. Board		
R217	VRD-SS2EY683J	68K ohm		LX-BZ0237AFFB	Screw, Cabinet		
R218	VRD-ST2EY221J	220 ohm		LX-BZ0053AFFD	Bolt (5φ × 10mm)		
R219	VRD-SS2EY560J	56 ohm		LX-NZ0121AFFD	Flange Nut, Speaker		
R220	VRD-SS2EY471J	470 ohm		LX-WZ3017CEFN	Shakeproof Lockwasher External Type, P.W. Board		
R221	VRD-SS2EY183J	18K ohm		LX-WZ9054AFZZ	Washer, Channel Dial		
R222	VRD-SS2EY333J	33K ohm		MSPRP0175AFFN	Plate Spring, Channel Indication Lamp		
R223	VRD-SS2EY102J	1K ohm		PCOVS0059AAZZ	Cover, P.L.L. Circuit P.W. Board		
R224	VRD-SS2EY680J	68 ohm		PCOVM8055AF00	Cover, ANL and Delta Tuning Switches, Rubber		
R225	VRD-SS2EY561J	560 ohm		PCAPH0001AGZZ	Cap, ANL Switch		
R226	VRD-SS2EY471J	470 ohm		PCOVU1104AF00	Cover, Channel Indication, Black		
R227	VRD-SS2EY560J	56 ohm		PGUMM0041AG09	Holder, Meter, Rubber		
R228	VRD-SS2EY222J	2.2K ohm		PGUMS0110AF00	Cushion, P.L.L. Unit, Rubber		
R229	VRD-SS2EY222J	2.2K ohm		PHAG-001MAFFC	Hanger, Microphone		
R301	VRD-ST2EE123J	12K ohm		PRDAR0144AFFW	Heat Sink, Transistors (Q303 and Q304)		
R302	VRD-ST2EE222J	2.2K ohm		PRDAR0145AFFW	Heat Sink, Integrated Circuit IC101		
R303	VRD-ST2EE221J	220 ohm		PSPAG0057AF00	Rubber Washer, Mounting Bracket		
R304	VRD-ST2EE223J	22K ohm		CNP101	QCNCM0402SGZZ	Plug, 4 Pin, Microphone	
R305	VRD-ST2EE470J	47 ohm		CNP701	QCNCM111KAFZZ	Plug, 10 Pin (U-bend)	
R306	VRD-ST2EE332J	3.3K ohm		CNP702	QCNCM155GAFZZ	Plug, 7 Pin (U-bend)	
R307	VRD-ST2EE101J	100 ohm		CNS101	QCNCM155GAFZZ	Connecting Cord with Socket (4 Pin), Microphone	
R308	VRD-ST2EE101J	100 ohm		CNS701, CNS702	QCNCM155GAFZZ	Connecting Cord with Socket (10 Pin and 7 Pin) and Plug (10 Pin and 7 Pin) Assembly	
R309	VRD-ST2EE680J	68 ohm		CNS701, CNS702	QCNCM155GAFZZ	Connecting Cord with Socket (10 Pin and 7 Pin) and Plug (10 Pin and 7 Pin) Assembly	
R310	VRD-ST2HA220J	22 ohm, 1/2W, ±5%, Carbon		CNS701, CNS702	QCNCM155GAFZZ	Connecting Cord with Socket (10 Pin and 7 Pin) and Plug (10 Pin and 7 Pin) Assembly	
R312	VRD-ST2HA471J	470 ohm, 1/2W, ±5%, Carbon		CNS701, CNS702	QCNCM155GAFZZ	Connecting Cord with Socket (10 Pin and 7 Pin) and Plug (10 Pin and 7 Pin) Assembly	
R313	VRD-ST2EE332J	3.3K ohm		CNS701, CNS702	QCNCM155GAFZZ	Connecting Cord with Socket (10 Pin and 7 Pin) and Plug (10 Pin and 7 Pin) Assembly	
R314	VRD-ST2EE472J	4.7K ohm		CNS701, CNS702	QCNCM155GAFZZ	Connecting Cord with Socket (10 Pin and 7 Pin) and Plug (10 Pin and 7 Pin) Assembly	
R315	RVR-M0129AFZZ	30K (B) ohm, RF Power Meter Adjust		CNS701, CNS702	QCNCM155GAFZZ	Connecting Cord with Socket (10 Pin and 7 Pin) and Plug (10 Pin and 7 Pin) Assembly	
R516	VRS-PT3AB331K	330 ohm, 1W, ±10%, Oxide Film		CNS701, CNS702	QCNCM155GAFZZ	Connecting Cord with Socket (10 Pin and 7 Pin) and Plug (10 Pin and 7 Pin) Assembly	
R517	VRD-ST2HA681J	680 ohm, 1/2W, ±5%, Carbon		CNS701, CNS702	QCNCM155GAFZZ	Connecting Cord with Socket (10 Pin and 7 Pin) and Plug (10 Pin and 7 Pin) Assembly	
R701	VRD-ST2HA470K	47 ohm, 1/2W, ±10%, Carbon		CNS701, CNS702	QCNCM155GAFZZ	Connecting Cord with Socket (10 Pin and 7 Pin) and Plug (10 Pin and 7 Pin) Assembly	
R702	VRD-ST2EY682J	6.8K ohm		CNS701, CNS702	QCNCM155GAFZZ	Connecting Cord with Socket (10 Pin and 7 Pin) and Plug (10 Pin and 7 Pin) Assembly	
R703	VRD-ST2EY332J	3.3K ohm		CNS701, CNS702	QCNCM155GAFZZ	Connecting Cord with Socket (10 Pin and 7 Pin) and Plug (10 Pin and 7 Pin) Assembly	
R704/ SW703, SW704	RVR-B0131AFZZ	Squelch Volume (10K-B ohms) with P.A. (Public Address) Switch		CNS701, CNS702	QCNCM155GAFZZ	Connecting Cord with Socket (10 Pin and 7 Pin) and Plug (10 Pin and 7 Pin) Assembly	
R705/ SW705	RVR-D0107AFZZ	50K (D) ohms, Off/Volume Control		CNS701, CNS702	QCNCM155GAFZZ	Connecting Cord with Socket (10 Pin and 7 Pin) and Plug (10 Pin and 7 Pin) Assembly	
R706	VRD-ST2EY122J	1.2K ohm		CNS701, CNS702	QCNCM155GAFZZ	Connecting Cord with Socket (10 Pin and 7 Pin) and Plug (10 Pin and 7 Pin) Assembly	
R707	VRD-ST2EY104J	100K ohm		CNS701, CNS702	QCNCM155GAFZZ	Connecting Cord with Socket (10 Pin and 7 Pin) and Plug (10 Pin and 7 Pin) Assembly	
R708	VRD-ST2EY104J	100K ohm		CNS701, CNS702	QCNCM155GAFZZ	Connecting Cord with Socket (10 Pin and 7 Pin) and Plug (10 Pin and 7 Pin) Assembly	
R709	RVR-M0148AFZZ	5K (B) ohm, Deepest Point Adjust		CNS701, CNS702	QCNCM155GAFZZ	Connecting Cord with Socket (10 Pin and 7 Pin) and Plug (10 Pin and 7 Pin) Assembly	
R710	VRD-ST2HA470K	47 ohm, 1/2W, ±10%, Carbon		CNS701, CNS702	QCNCM155GAFZZ	Connecting Cord with Socket (10 Pin and 7 Pin) and Plug (10 Pin and 7 Pin) Assembly	
				CNP501	QCNCM155GAFZZ	Connecting Cord with Socket, Speaker	
				QFS-A232AAFNA	Fuse, 2.3 Ampere		
				QFSHJ9052AFZZ	Power Supply Cord with Fuse Holder and Socket		

# PARTS LIST

REF. NO.	PART NO.	DESCRIPTION	PRICE	REF. NO.	PART NO.	DESCRIPTION	PRICE	
J601-A, B	QJAKB0050AFZZ	Jacks, External Speaker (J601-A) and P.A. Speaker (J601-B)		SW703,	RVR-B0131AFZZ	Switch, P.A. (Public Address) with Squelch Volume (10K-B ohms)		
	QPWBF0052AAZZ	Printed Wiring Board, P.L.L. Circuit		SW704/ R704		RVR-D0107AFZZ	50K (D) ohms, Off/Volume Control	
	QPWBF0612AFZZ	Printed Wiring Board, Main Circuit		SW705/ R705			RC-KZ1009AFZZ	Feed Through Capacitors with Bracket
	QPWBF0616AFZZ	Printed Wiring Board, Volume Circuit		C606, C607		RCORF0051AFZZ		Ferrite Core
PG201	QPLGZ0850AFZZ	Plug, 8 Pin		PL701	RLMPM0019AGZZ	Lamp, Meter Illumination		
PG202	QPLGZ0850AFZZ	Plug, 8 Pin		PL702	RLMPM0019AGZZ	Lamp, Channel Indication		
	QSOCE0401AFZZ	Socket, Test Point <span style="border: 1px solid black; padding: 0 2px;">TP308</span> and <span style="border: 1px solid black; padding: 0 2px;">TP309</span>			RMICD0213AFZZ	Microphone Assembly (with Press-to-talk Switch)		
	QPLGE0403AGZZ	Plug, Test Point <span style="border: 1px solid black; padding: 0 2px;">TP308</span> and <span style="border: 1px solid black; padding: 0 2px;">TP309</span>		ME701	RMTRE0063AFZZ	Meter, Signal/RF Power		
PG601	QSOCZ2454AFZZ	Plug, Power Supply			RTUNS0050AFZZ	P.L.L. Unit		
SO101	QSOCZ2468AFZZ	Socket, Microphone			SPAKC1010AFZZ	Packing Case		
SO401	QSOCZ2470AFZZ	Socket, External Antenna (50 ohms)			SSAKZ0053AFZZ	Polyethylene Bag, Set		
					TINSE0505AFZZ	Operation Manual		
SW101- A ~ D/ RY601	RRLYZ0007AFZZ	Relay with Receiver/Transmitter Switch		SP601	VSP0080P-288A	Speaker, 8 ohms, 8cm		
					XBBSC30W08000	Screw, 3φ x 8mm, Microphone Hanger		
					XNESD50-40000	Nut (5φ)		
SW201	QSW-R0144AFZZ	Switch, Channel Selector			XWHSD50-05000	Washer (5φ)		
SW701	QSW-B0003AFZZ	Switch, Delta Tuning			XWSSD50-13000	Spring Washer (5φ)		
SW702	QSW-B0028AGZZ	Switch, ANL (Automatic Noise Limiter)						